

FUEL PUMP - INSPECTION/CHECK

1. General

A. This section provides inspection criteria for the fuel pump.

2. Fuel Pump Inspection

A. Fuel Pump Inspection (Refer to Figure 601).

- (1) Remove the drain line and fitting from the fuel pump seal drain port.
- (2) Insert a suitable cotton swab into the port, wiping the internal passage wall above the threads.
- (3) Remove the swab and examine it for presence of a reddish brown (iron-oxide) stain. If none is evident, the unit may continue in service.
- (4) Install fitting and drain line.
- (5) If stain is found, remove pump from engine.
- (6) Examine the pump face, input coupling side, for residue from fretting corrosion (iron-oxide deposits) in the area shown in Inspection Area B. If none is present the pump may be reinstalled.
- (7) If a fretting corrosion residue is present, this indicates excessive spline wear and the pump must be forwarded to an approved facility for overhaul/repair. Install a replacement pump in accordance with paragraph B.

CAUTION: Do not remove the coupling as this may cause chipping of the splines and/or loss of circlip retention with detrimental effect. The circlip allows very limited movement of the coupling.

B. Fuel Pump Installation.

- (1) Prior to installation of a time-continued or replacement pump, accomplish the following:
 - (a) Check for presence of oil on the coupling splines of the removed pump, and ensure that the hole in the gearbox drive shaft (Inspection Area C) is free of obstruction. This hole may be cleaned with a length of MS9226-03 lockwire, or equivalent.
 - (b) Ensure that the shaft and coupling splines are free of grease or similar lubricant.
- (2) The shaft and coupling splines are to be liberally coated with engine oil only. Install pump on the engine.
- (3) This coupling inspection should be entered in the airplane log book.

Figure 601 : Sheet 1 : Engine Driven Fuel Pump Inspection

A21751

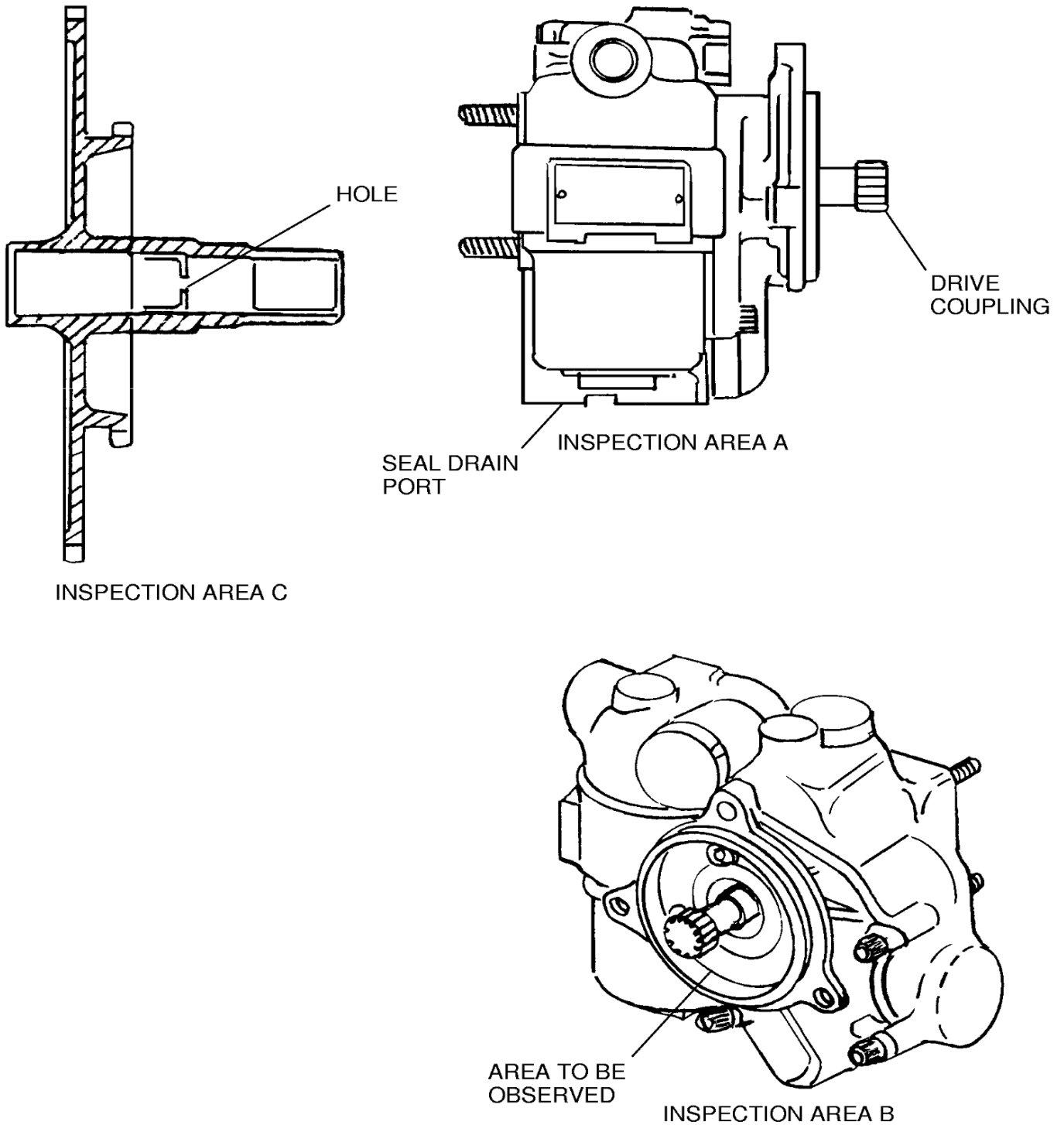

26561021